

See discussions, stats, and author profiles for this publication at: <https://www.researchgate.net/publication/343818840>

# Comparison of Accurate Control Techniques for DSTATCOM

Research · August 2020

DOI: 10.13140/RG.2.2.17239.70566

---

CITATIONS

0

READS

77

3 authors, including:



**P.Santosh Kumar Patra**

ST. MARTIN'S ENGINEERING COLLEGE

30 PUBLICATIONS 0 CITATIONS

SEE PROFILE

Some of the authors of this publication are also working on these related projects:



Power Quality [View project](#)

## Comparison of Accurate Control Techniques for DSTATCOM

Dr.P.Santosh Kumar Patra<sup>1</sup>, Dr.N.Ramchandra<sup>2</sup>

<sup>1</sup>Principal & Professor in CSE, St. Martin's Engineering College, Secunderabad, Telangana, India

<sup>2</sup>Professor in EEE, St. Martin's Engineering College, Secunderabad, Telangana, India

<sup>1</sup>principal@smec.ac.in, <sup>2</sup>ramceee@smec.ac.in

### Abstract

The distribution power systems are accumulated with different power quality problems like harmonics, low power factor etc. due to invariant inductive loads. The effective device used to mitigate these power quality problems is Distribution Static Compensator (DSTATCOM). The control algorithm present in the building block of DSTATCOM plays a vital role in the efficient operation of DSTATCOM. Hence choosing a proper control algorithm for DSTATCOM is always an important aspect. In this paper four accurate control algorithms for DSTATCOM are proposed. These control algorithms are compared for different loading conditions on a test distribution power system. Based on the comparative analysis, the appropriate control algorithm for DSTATCOM is finalized.

**Keywords**— DSTATCOM, Voltage Source Inverter (VSI), Reference currents, power factor, Harmonics.

### 1. Introduction

DSTATCOM is the most effective device in the distribution network to overcome the problems like low power factor, high reactive power consumption, voltage distortions due to current harmonics, unbalanced loading [1]. The most significant component of DSTATCOM is the control algorithm present inside the building block of DSTATCOM.

Generally, there are two control methods, direct and indirect control methods. In indirect control method, the reference currents are generated by controlling the magnitude and phase of the output voltage of the converter. It uses Pulse Amplitude Modulation (PAM) or Pulse width Modulation (PWM) to generate firing pulses for IGBT based voltage source Inverter (VSI). The direct control method involves current regulated PWM techniques like hysteresis current control to implement the instantaneous current feedback [3]. Many control algorithms for DSTATCOM are proposed in the literature survey to improve the power quality in distribution systems [4].

In this paper four accurate control algorithms; Instantaneous reactive power theory (IRP), unit template algorithm, modified P-Q theory and dead beat predictive control, among the various control techniques of DSTATCOM are proposed. These algorithms are compared in different inductive loading conditions for various parameters. By observing the comparative analysis, the suitable control technique will be identified. The next section discusses about the proposed control techniques.

### 2. Control Algorithms

It controls the output voltage of VSI and used for the extraction of reference currents and these reference currents are compared with hysteresis current controller to generate firing pulses for IGBT based VSI.

#### 2.1 Instantaneous Reactive Power Theory

This theory is based on instantaneous values and has two control strategies constant instantaneous supply power and sinusoidal supply current. For reactive power compensation the entire reactive power and a component of the active power are utilized as the reference powers [5]. From these the reference currents are calculated as

$$\begin{bmatrix} i_{cd}^* \\ i_{cq}^* \end{bmatrix} = \frac{1}{V_d^2 + V_q^2} \begin{bmatrix} V_d & V_q \\ -V_q & V_d \end{bmatrix} \begin{bmatrix} p_c^* \\ q_c^* \end{bmatrix} \tag{1}$$

From inverse Clarke’s transformation the three phase reference currents are

$$\begin{bmatrix} i_{ca}^* \\ i_{cb}^* \\ i_{cc}^* \end{bmatrix} = \sqrt{\frac{2}{3}} \begin{bmatrix} 1 & 0 \\ -1 & \sqrt{3} \\ -1 & -\sqrt{3} \end{bmatrix} \begin{bmatrix} i_{cd}^* \\ i_{cq}^* \end{bmatrix} \tag{2}$$

**2.2 Unit Template Algorithm**

The Unit template algorithm is a simple method for the generation of reference currents [6]. This algorithm uses unit templates instead of standard phase locked loop (PLL) which is used for the extraction of synchronizing components in Synchronous reference method (SRF).

The unit templates in phase with PCC voltages  $U_{ap}$ ,  $U_{bp}$ ,  $U_{cp}$  are

$$U_{ap} = \frac{V_a}{V_t}; \quad U_{bp} = \frac{V_b}{V_t}; \quad U_{cp} = \frac{V_c}{V_t} \tag{3}$$

The unit templates in quadrature with PCC voltages  $U_{aq}$ ,  $U_{bq}$ ,  $U_{cq}$  are

$$\begin{aligned} U_{aq} &= \frac{-U_{bp} + U_{cp}}{\sqrt{3}}; \\ U_{bq} &= \frac{\sqrt{3}}{2} U_{ap} + \frac{U_{bp} - U_{cp}}{2\sqrt{3}}; \\ U_{cq} &= -\frac{\sqrt{3}}{2} U_{ap} + \frac{U_{bp} - U_{cp}}{2\sqrt{3}} \end{aligned} \tag{4}$$

Using unit templates voltage equations, the total three phase reference source currents  $I_{sa}^*$ ,  $I_{sb}^*$ ,  $I_{sc}^*$  are

$$\begin{aligned} I_{sa}^* &= I_{ap}^* + I_{aq}^*; \\ I_{sb}^* &= I_{bp}^* + I_{bq}^*; \\ I_{sc}^* &= I_{cp}^* + I_{cq}^* \end{aligned} \tag{5}$$

**2.3 Modified p-q Theory**

This algorithm is derived by modifying the Instantaneous Reactive Power Theory (IRP) to control the DSTATCOM for various non-linear inductive loads. Here the reference currents are generated from unit templates and instantaneous active, reactive powers [7]. Therefore the instantaneous active power and reactive powers of the load from unit template voltage equations are

$$\begin{aligned} P_1 &= V_t (U_{ap} i_a + U_{bp} i_b + U_{cp} i_c) \\ Q_1 &= V_t (U_{aq} i_a + U_{bq} i_b + U_{cq} i_c) \end{aligned} \tag{6}$$

Then, the total three phase reference source currents obtained from this theory are

$$I_{sa}^* = I_{ap}^* + I_{aq}^*; \quad I_{sb}^* = I_{bp}^* + I_{bq}^*; \quad I_{sc}^* = I_{cp}^* + I_{cq}^* \tag{7}$$

**2.4 Dead beat predictive control algorithm**

The deadbeat predictive control algorithm uses discrete modeling of the system to calculate the reference currents in order to reach the desired value of load current [8]. From instantaneous symmetrical component theory, the positive sequence voltages ,  $V_{1a}$   $V_{1b}$   $V_{1c}$ , are calculated. Using these voltages the reference currents of VSI ,  $i_{fa}^*$   $i_{fb}^*$   $i_{fc}^*$ , and capacitor currents are computed.

$$\begin{aligned}
 i_{fa}^* &= I_a - \frac{V_a}{V_{a1}^2 + V_{b1}^2 + V_{c1}^2} (P_1 + P_{avg}); \\
 i_{fb}^* &= I_b - \frac{V_b}{V_{a1}^2 + V_{b1}^2 + V_{c1}^2} (P_1 + P_{avg}); \\
 i_{fc}^* &= I_c - \frac{V_c}{V_{a1}^2 + V_{b1}^2 + V_{c1}^2} (P_1 + P_{avg})
 \end{aligned}
 \tag{8}$$

$$\begin{bmatrix} i_{ca}^* \\ i_{cb}^* \\ i_{cc}^* \end{bmatrix} = j\omega C_{fc} \begin{bmatrix} V_{A1} \\ V_{B1} \\ V_{C1} \end{bmatrix}
 \tag{9}$$

Therefore the three phase reference filter currents are

$$\begin{bmatrix} i_{ia}^* \\ i_{ib}^* \\ i_{ic}^* \end{bmatrix} = \begin{bmatrix} i_{fa}^* \\ i_{fb}^* \\ i_{fc}^* \end{bmatrix} + \begin{bmatrix} i_{ca}^* \\ i_{cb}^* \\ i_{cc}^* \end{bmatrix}
 \tag{10}$$

The performance of DSTATCOM in current control mode (CCM) mainly depends upon generation of these filter currents. The generation of reference load currents from these equations is

$$\begin{aligned}
 u_a^*(k) &= \frac{i_{ia}^*(k+1) - G_{21}V_{fc}(k) - G_{22}i_{ia}^*(k) - H_{21}i_{fa}^*(k)}{H_{22}} \\
 u_b^*(k) &= \frac{i_{ib}^*(k+1) - G_{21}V_{fc}(k) - G_{22}i_{ib}^*(k) - H_{21}i_{fb}^*(k)}{H_{22}} \\
 u_c^*(k) &= \frac{i_{ic}^*(k+1) - G_{21}V_{fc}(k) - G_{22}i_{ic}^*(k) - H_{21}i_{fc}^*(k)}{H_{22}}
 \end{aligned}
 \tag{11}$$

Where = initial voltage across the capacitor.  $V_{fc}$ .

$G_{21}$  ,  $G_{22}$  ,  $H_{21}$ ,  $H_{22}$  are the matrices obtained from the modeling of the DSTATCOM.

With these proposed algorithms, the performance of DSTATCOM is tested with three phase rectifier RL load, inductive load and an induction motor. The performance of the algorithms is observed with respect to the parameters like harmonics, power factor. Finally the effective algorithm which suits DSTATCOM is concluded.

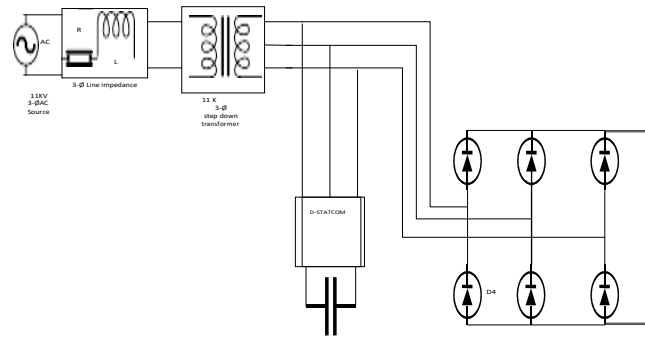
**3. Simulation Results**

The considered test distribution system is supplied with an 11Kv, 3-φ ac source. The

voltage is step down to 415V using 3- $\phi$ , 11KV /415V step down transformer. In this paper three different inductive nonlinear loads; three phase rectifier RL load, high reactive load and an induction motor are considered in three different cases. In all the three cases the control algorithms are compared w.r.to the voltage harmonics, current harmonics, current and power factor.

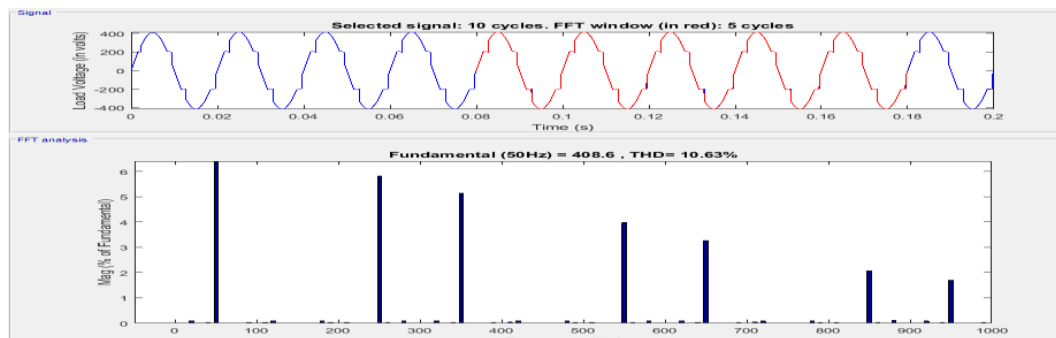
**Case I: Performance of DSTATCOM under rectifier load**

The schematic diagram of the distribution line with DSTATCOM for rectifier load is simulated in MATLAB as shown in Fig.1.

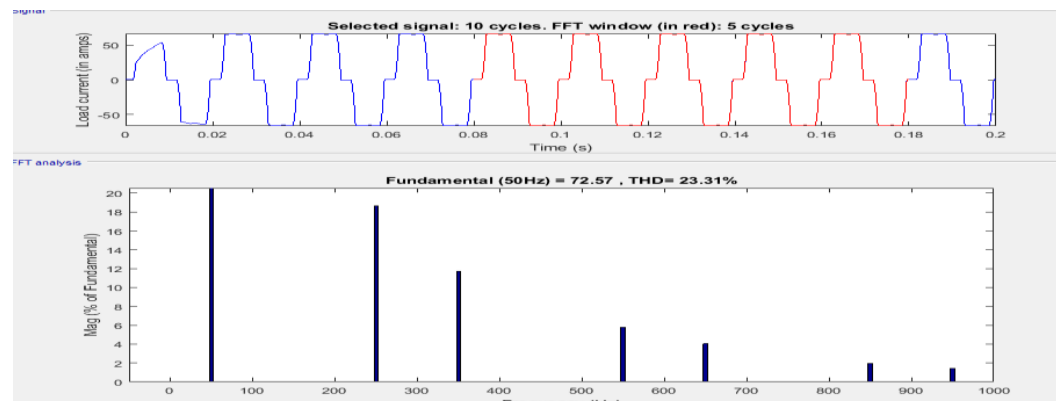


**Figure. 1. Distribution line with DSTATCOM for rectifier load**

In the absence of DSTATCOM, the total harmonic distortions of load voltage are 10.63% and load current is 23.31% for the rectifier load as shown in Fig.2



**Figure 2(a) Load voltage THD without DSTATCOM=10.63%**

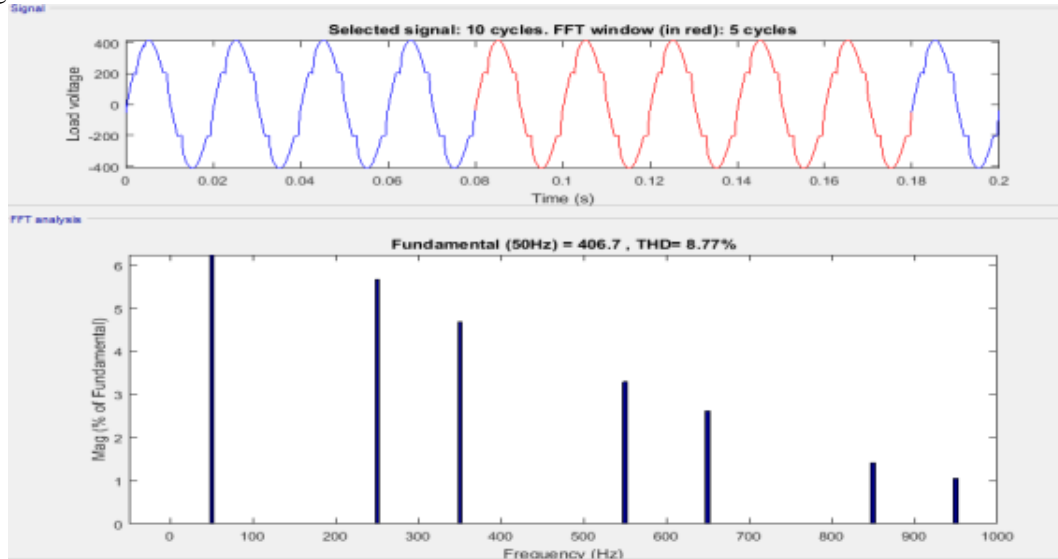


**Figure 2(b) Load current THD without DSTATCOM=23.31%**

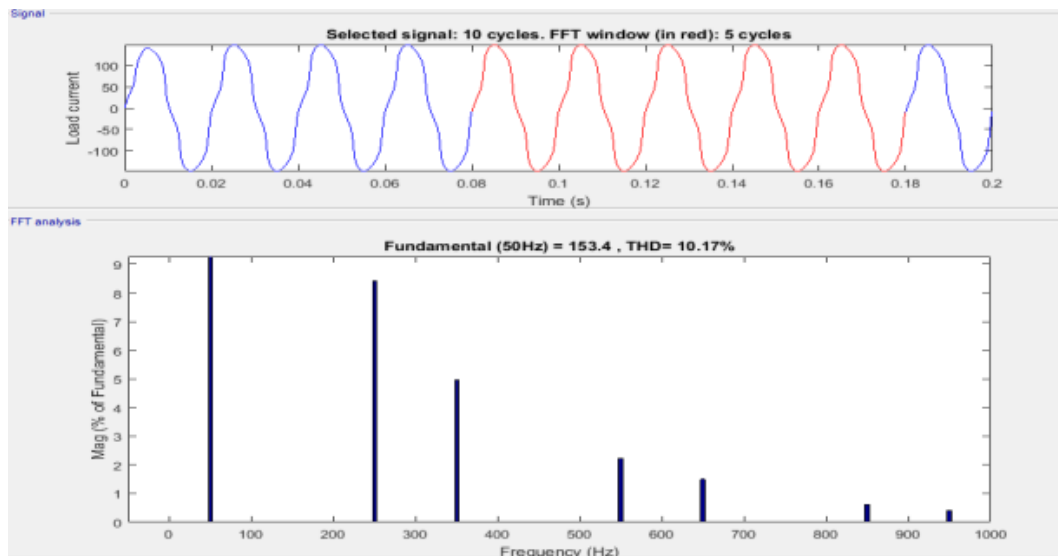
In order to reduce harmonics in load voltage and load current DSTATCOM is connected in parallel to the distribution line.

**A. DSTACOM with Unit Template algorithm**

Due to rectifier load connected to the system, harmonics are produced in load voltage and load current waveforms as shown in Fig. 2. When DSTACOM with Unit Template algorithm is connected to the system it reduces the harmonics from load voltage and load current as shown in Fig. 3.



**Figure 3 (a) Load voltage THD without DSTACOM=8.77%**



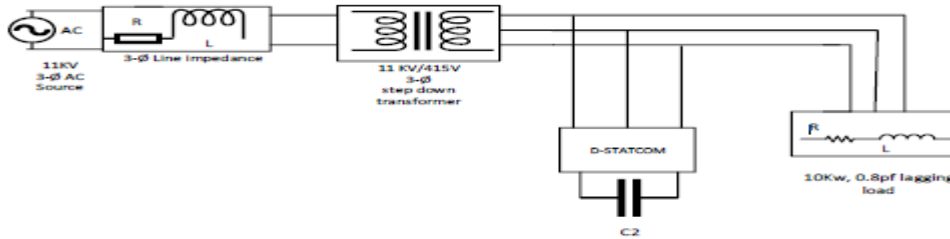
**Figure 3 (b) Load current THD without DSTACOM=10.17%**

**Figure 3 THD analysis of load voltage and current with DSTACOM for unit template algorithm**

The THD in the presence of DSTACOM with four control algorithms are given in table 1.

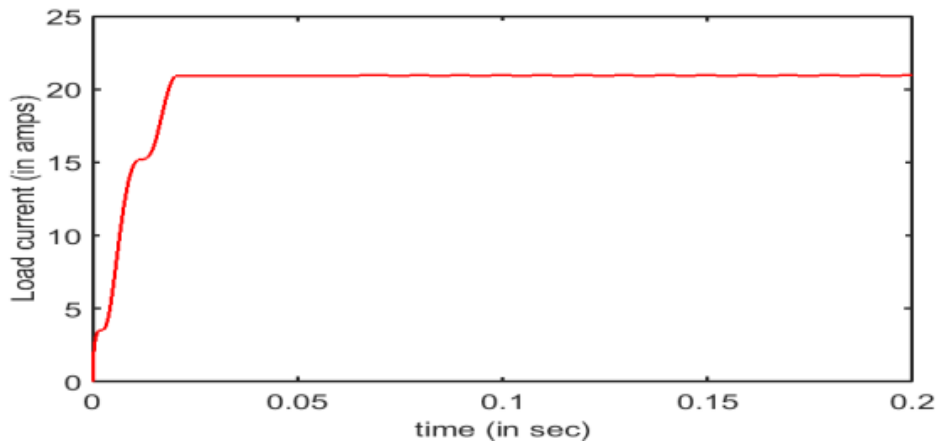
**Case II: Performance of DSTATCOM under R-L load**

The schematic diagram of the distribution line with DSTATCOM for high reactive load 10Kw, 0.8Pf lagging is simulated in MATLAB as shown in Fig.4.

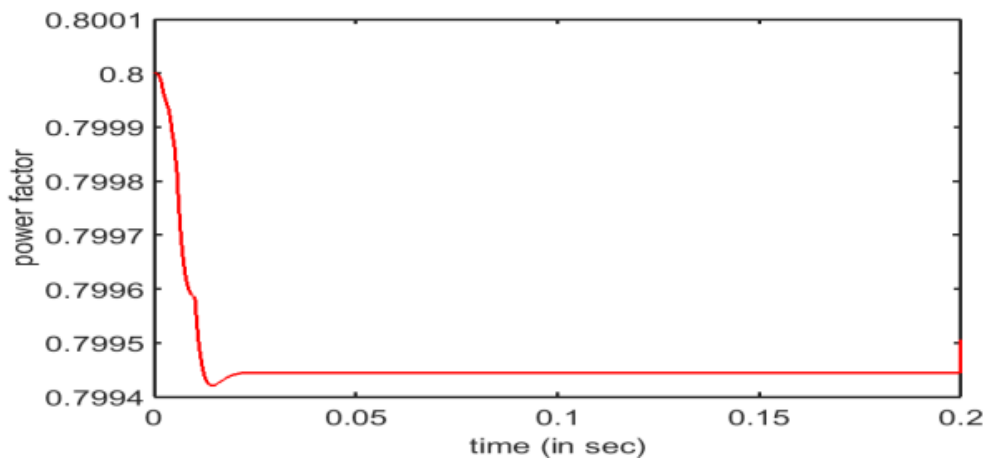


**Figure 4. Distribution line with DSTATCOM for R-L load**

In the absence of DSTATCOM, the load current reduces to 20A and power factor reduces to 0.79 for high reactive R-L load as shown in Fig.5



**Figure 5 (a) Load current**



**Figure 5 (b) Load power factor**

**Figure 5 Load current and power factor without DSTATCOM**

### A. Unit Template Algorithm

Due to R-L load connected to the system, the magnitude of load current decreased and became unbalanced which also reduces the power factor as shown in Fig. 5. When DSTATCOM with unit template algorithm is connected to the system it makes load current balanced and improves power factor as shown in Fig.6

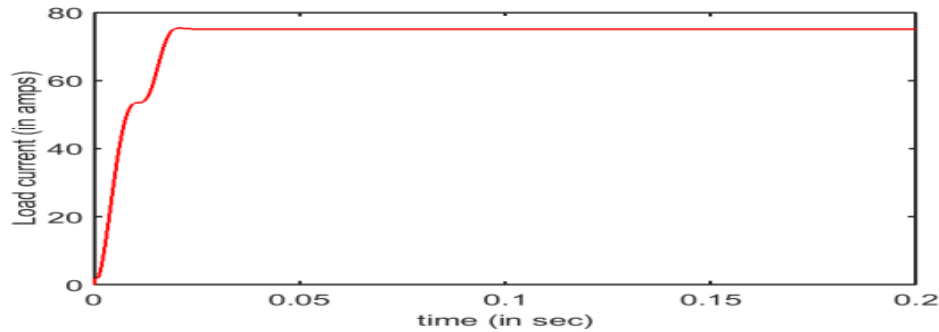


Figure 6(a) Load current

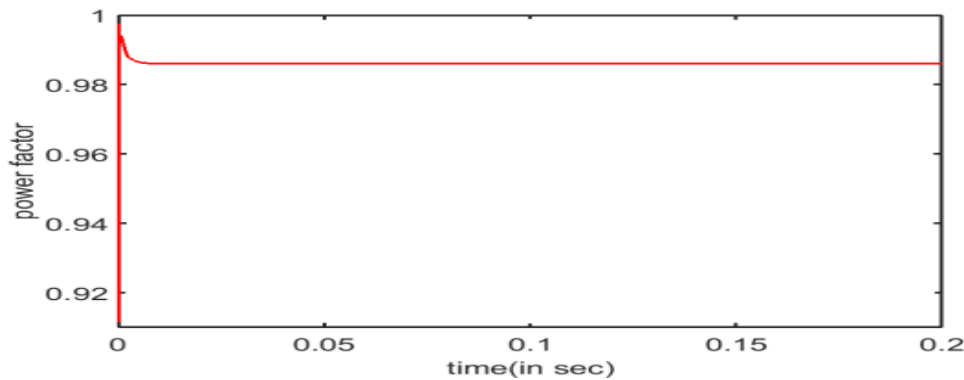


Figure 6(b) power factor

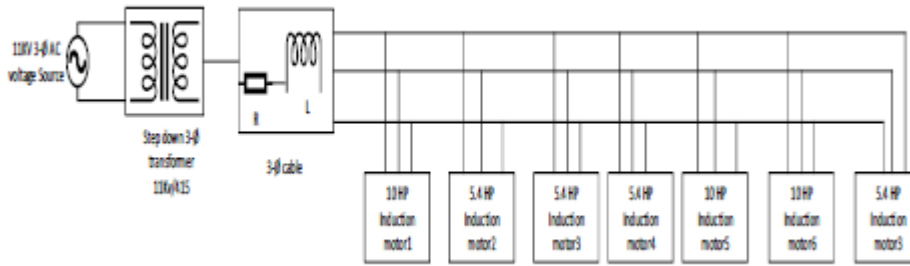
Figure 6 Load current and power factor with DSTATCOM for unit template algorithm

The THD, load current and power factor in the presence of DSTATCOM with four control algorithms are given in Table 1.

### Case III: Performance of Distribution line under motor load without DSTATCOM

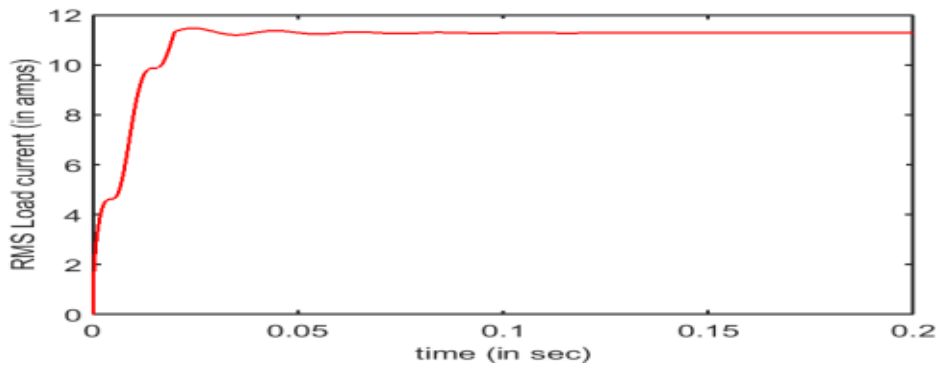
Here the distribution line is connected to seven induction motors of different ratings as load. As motor load connected to the system, the magnitude of load current decreased and became unbalanced which also reduces the power factor. "Fig. 7," shows the simulation diagram of the distribution line with induction motor load without DSTATCOM.



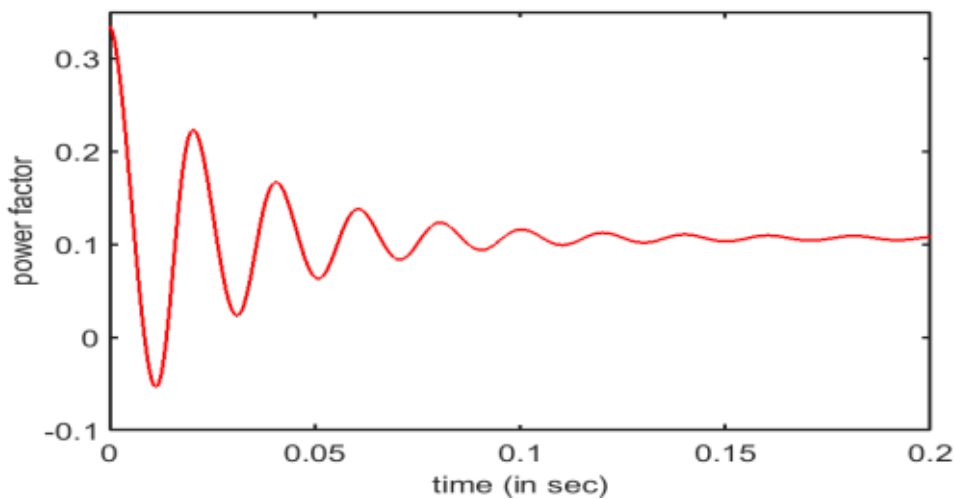


**Figure 7 Simulation diagram of distribution line with induction motor load**

In the absence of DSTATCOM, the load current reduces to 11A and power factor reduces to 0.1, oscillating as shown in Fig. 8.



**Figure 8 (a) Load current**

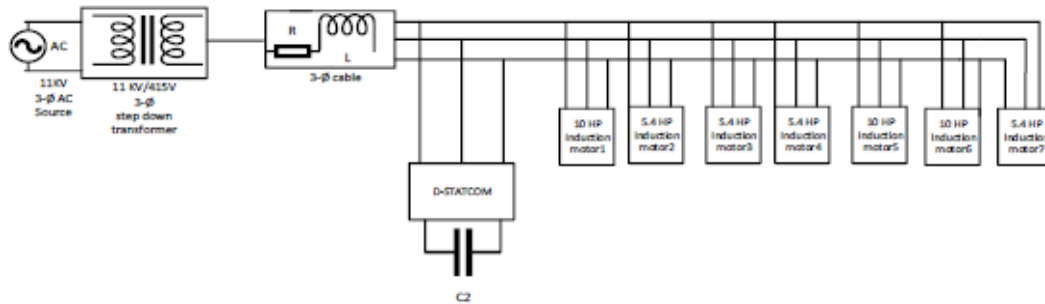


**Figure 8(b) Load power factor**

**Figure 8 Load current and power factor without DSTATCOM**

**A. Performance of Distribution line for motor load with DSTATCOM.**

In order to improve both load current and power factor DSTATCOM is connected in parallel to the distribution line as shown in Fig.9

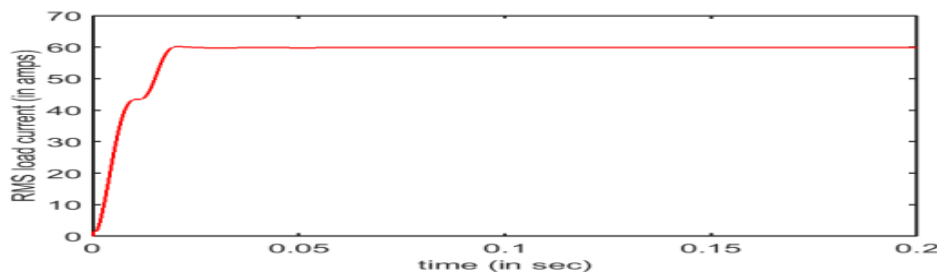


**Figure 9. Distribution line with D-STATCOM for Induction Motor loads**

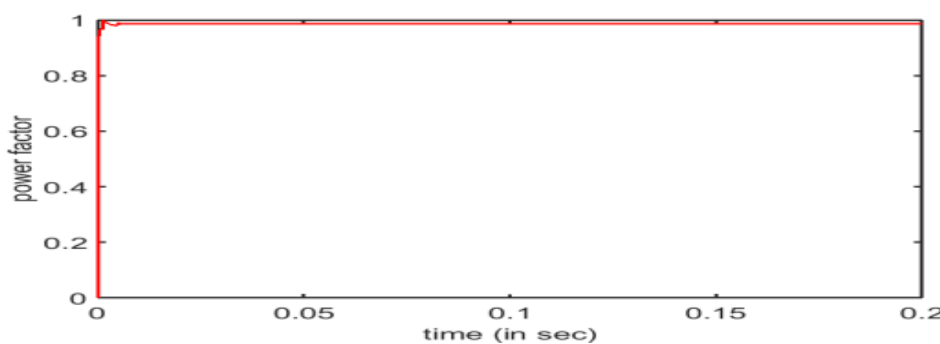
The operation of DSTATCOM in distribution line with different ratings of induction motor loads are compared for various control algorithms to choose appropriate one

**a) Instantaneous Reactive power theory**

As the induction motor load connected to the system, the magnitude of load current decreased and became unbalanced which also reduces the power factor as shown in Fig. 2. When DSTATCOM with Instantaneous reactive power theory is connected to the system it makes load current balanced and improves power factor as shown in Fig. 10.



**Figure 10 (a) Load current**



**Figure 10 (b) power factor**

**Figure 10 Load current and power factor with DSTATCOM for Instantaneous reactive power theory**

#### 4. Comparitive Results

For the above three loads the distribution line along with DSTATCOM (for different control algorithms) is simulated and the comparative analysis is tabulated in Table.1.

TABLE 1 Load current, power factor and THD of Load voltage, current under non-linear loads

Load	compensation	Instantaneous reactive power (IRP) theory	Unit template algorithm	Modified p-q theory	Dead beat predictive control
Rectifier load	Load current	109	109	108.5	108.8
	Power factor	0.97	0.98	0.98	0.97
	Load Voltage THD (%)	8.78	8.77	8.79	9.11
	Load current THD (%)	10.13	10.17	11	10.46
R-L load	Load current	75.1	75.1	74.6	74.7
	Power factor	0.98	0.98	0.98	0.98
	Load Voltage THD (%)	0.02	0.02	1.02	0.16
	Load current THD (%)	0.02	0.02	1.01	0.14
Induction motor load	Load current	60	60	60	60
	Power factor	0.98	0.98	0.97	0.98
	Load Voltage THD (%)	0.02	0.26	0.06	0.18
	Load current THD (%)	0.02	0.44	0.12	0.19

From the Table.1 it is shown that for rectifier and R-L loads both IRP theory and unit template algorithms gives same results for all the four parameters. In view of execution time, the unit template algorithm is the preferred algorithm for DSTATCOM because it also reduces the reactive power burden on DSTATCOM. Specifically for the induction motor load the IRP theory can be preferred because it gives balanced load voltage and load current without harmonics. Overall IRP theory, Unit template algorithms are preferable algorithms for DSTATCOM for any load conditions in distribution systems.

#### 5. Conclusion

DSTATCOM is a D-FACTS device used to mitigate the power quality problems. In this paper different control algorithms for DSTATCOM are proposed and compared at different loading conditions in a test power system. Among them proposed control techniques, the instantaneous reactive power theory and unit template algorithms have resulted in considerable improved performance for the DSTATCOM for all the proposed loads and for improving the power quality in distribution systems.

## References

- [1] P. Bapaiah, "Power Quality Improvement By Using DSTATCOM", International Journal of Emerging Trends in Electrical and Electronics(IJETEE),Vol.2,Issue.4,April-2013.
- [2] K. Sandhya, Dr. A. Jayalaxmi, Dr. M.P. Soni, "Direct and Indirect Control Strategies of DSTATCOM Power Factor Controller", International Journal of Engineering Research and Applications (IJERA) ISSN:2248-9622.
- [3] Tan Tian-yuan, Jiang Qi-rong, Li Gang and Lai Yu-xiang, "Comparison of Direct and Indirect Current Control Strategy for DSTATCOM", 2006 International Conference on Power System Technology.
- [4] Bhim Singh, Senior Member, IEEE and Jitendra Solanki, "A Comparative Study of Control Algorithms for DSTATCOM for Load Compensation", 1- 4244- 0726-5/06/\$20.00 '2006IEEE.
- [5] Laxmikant Chauhan, Mrs.P.V. Mistri, "Instantaneous Power Control And Power Factor Improvement Using D-Statcom Device-Review" International Journal Of Applied Research In Science And Engineering ISSN (Online): 2456-124X.
- [6 ]Abhayrajsinh J. Rana, Chirag K. Vasoya, Mahesh H. Pandya, Piyushkumar M. Saradva," Application of Unit Template Algorithm for Voltage Sag Mitigation in Distribution Line Using D-STATCOM", 978-1-4673-9925-8/16/\$31.00 ©2016IEEE.
- [7] Bhim Singh, Fellow, IEEE, and Sunil Kumar," Modified Power Balance Theory for Control of DSTATCOM", 978-1-4244-7781-4/10/\$26.00 ©2010 IEEE
- [8]. Chandan Kumar, Student Member, IEEE, and Mahesh K. Mishra, Senior Member, IEEE," A Voltage-Controlled DSTATCOM for Power-Quality Improvement", 0885-8977 © 2014 IEEE.